



**ENGINEERED
RECYCLING
SYSTEMS**
EngineeredRecycling.com

HSCS

New Technology in the Separation World



Exceptional Parts and Service

Reduce downtime and boost equipment efficiency with our extensive spare parts inventory and expert service. Located in our 55,000-square-foot Atlanta hub, we ensure quick access to essential components, and our on-site repair services guarantee unmatched precision and reliability for seamless operations.



www.engineeredrecycling.com



info@engineeredrecycling.com

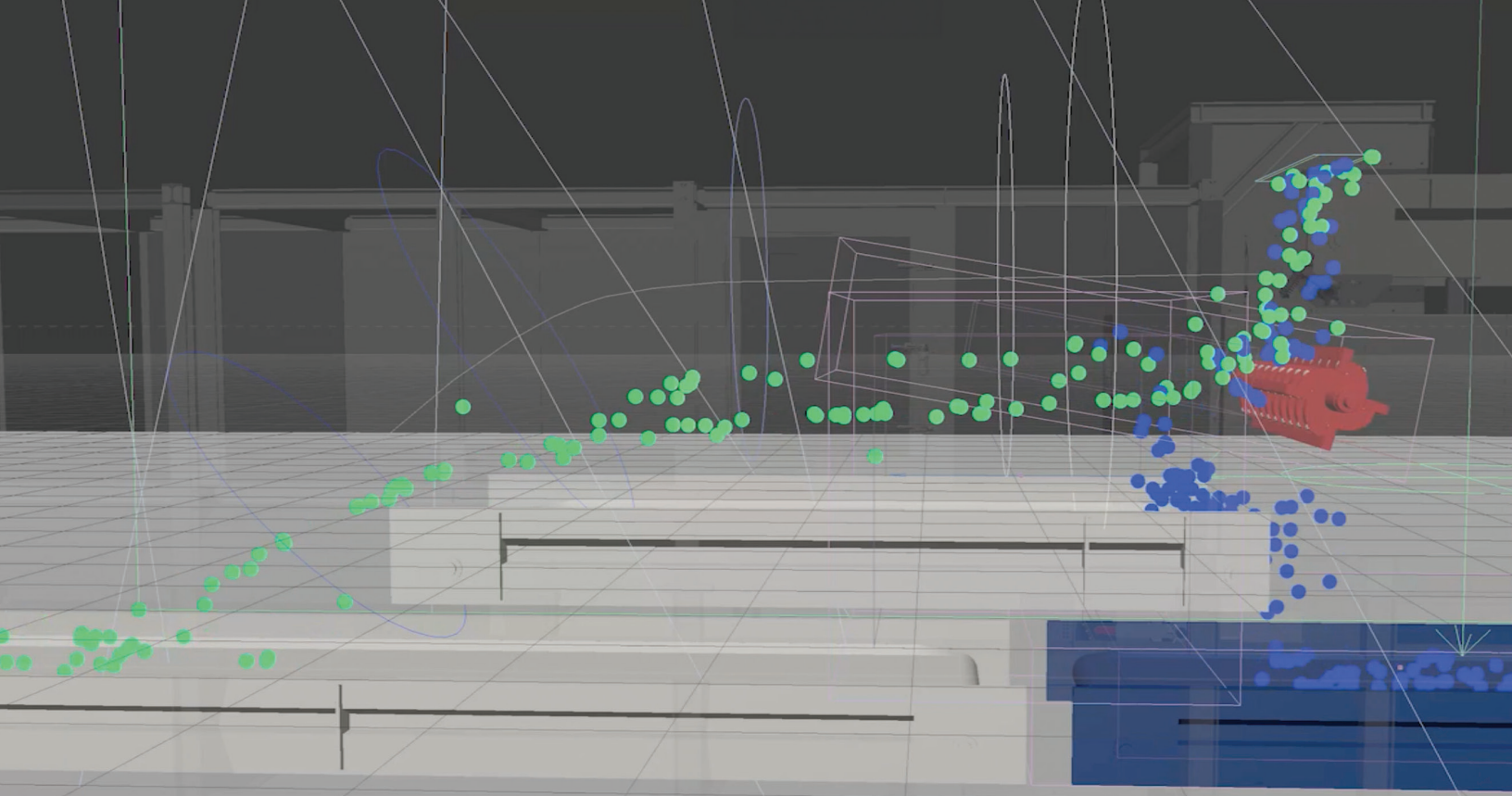

Innovative Separation Method

The HSCS operates on an advanced separation method that focuses on material properties rather than traditional techniques relying on density or grain size. This innovative approach allows HSCS to achieve remarkable separation cuts across a variety of materials, regardless of their moisture content or grain size.

Notable applications include:

- Films from Plastic
- Metal Fractions from Residuals

Input Streams Include:

- ASR/SLF
- Waste
- Plastic
- Slag
- And more!

Inside the HSCS – Separation Process in Action

Rotor Mechanism

The advanced rotor is essential for effective cleaning processes, such as slag treatment. It facilitates the separation of various materials by leveraging their unique properties rather than traditional density or grain size methods.

Material Feed Area

This is where input materials, including ASR/SLF, waste, plastic, and slag, are introduced into the system for processing.

Separation Chamber

The chamber is designed for optimal airflow and efficiency, ensuring materials are effectively separated and directed towards their respective outputs.

Output Streams

As materials are processed, the HSCS efficiently segregates films from plastic and metal fractions from residuals, showcasing its versatility and effectiveness.

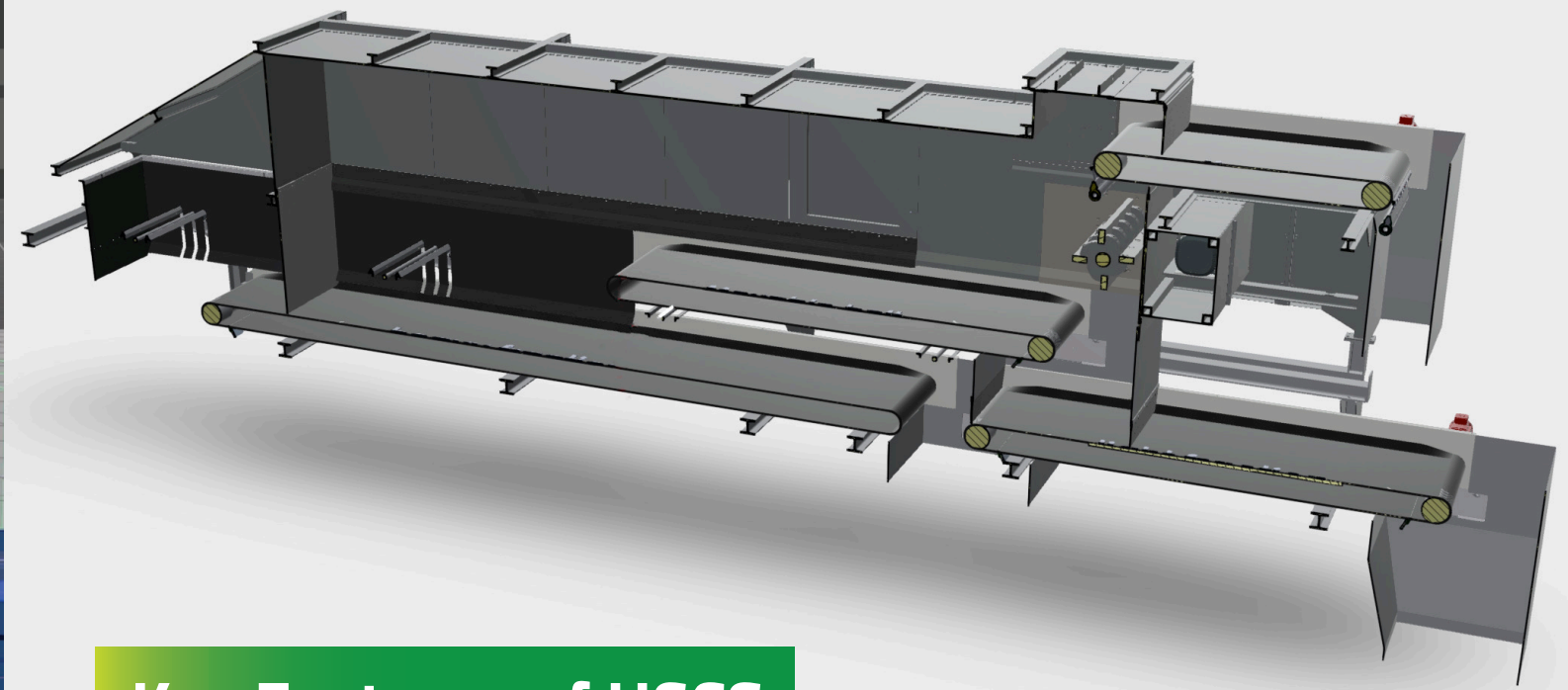

Key Features of HSCS

Wide Range of Applications: Designed for effective processing of diverse scrap materials.

- Extremely High Efficiency and Compatibility: Engineered to maximize performance across various types of materials.
- Quick and Easy Adjustments: Settings can be modified rapidly for seamless operation and efficiency.
- Low Energy Consumption: Optimized to minimize operational costs while maintaining high performance.
- Operational Adjustability: The machine can be adjusted during operation, ensuring peak performance at all times.
- Enhanced Efficiency in Downstream Processes: HSCS alleviates the workload of downstream high-end processes or shredding stages, allowing them to operate more efficiently.
- Effective Cleaning Processes: Achieve superior results in cleaning operations, such as slag treatment, using the advanced rotor mechanism.

Technical Specifications:

- Width: 800 to 2000 mm
- Drive of Shaft: E-motor, frequency controlled, up to 44 kW (depending on size)
- Drive of Ventilator: E-motor, frequency controlled, up to 75 kW (depending on size)
- Air Stream: Up to 50,000 m³/h (depending on size)

ALWAYS ONE STEP AHEAD IN METALS RECOVERY!

Get in Touch!

Discover how HSCS and our advanced recycling solutions can elevate your operations. Call us today for a personalized consultation!

Engineered Recycling Systems, LLC
5010 McDougall Dr. SW
Atlanta, GA 30336, USA
Phone: +1 770-830-4206
Email: info@engineeredrecycling.com

As the industry leader in dust collection, metal separation, and trim removal systems, Engineered Recycling Systems (ERS) is dedicated to providing the most innovative integrated systems on the market. Our team consists of top engineers and system integrators with extensive industry knowledge and expertise, ensuring optimal solutions for our customers.

Our Product Line Includes:

- Copper Wire and Cable Chopping Systems
- Millings-Tailings Processing Systems
- ASR Fines Processing Systems
- ASR & Car Fluff Recycling Systems
- Meatball & Armature Processing Systems
- ACR Chopping Systems
- ACSR Wire Chopping Systems

In a market where copper prices remain strong, partnering with ERS guarantees a reliable ally in maximizing your recycling revenues.



www.engineeredrecycling.com



info@engineeredrecycling.com



**ENGINEERED
RECYCLING
SYSTEMS**

EngineeredRecycling.com

The team at ERS is comprised of the industry's top engineers and system integrators. Incorporating the finest equipment technology, expansive industry knowledge and expertise. ERS provides customers with the latest and most innovative integrated systems in the world.